



Electrical Permit Application

Permit Label

Other Permits Required: Building Plumbing Gas PSDS Supply Service Required: Yes No

Permit Type: Owner Contractor Development Permit Number: _____

Application Date (M/D/Y): _____ Estimated Completion Date (M/D/Y): _____

Owner Name: _____ Mailing Address: _____
City: _____ Prov: _____ Postal Code: _____ Phone: _____
Alt Phone: _____ Email Address: _____ Fax: _____

Contractor: _____ Mailing Address: _____
City: _____ Prov: _____ Postal Code: _____ Phone: _____
Alt Phone: _____ Email Address: _____ Fax: _____

Municipality: _____ Street Address: _____
Unit #: _____ Lot: _____ Block: _____ Plan: _____ Subdivision or Hamlet _____
Legal Subdivision: Part of: _____ 1/4 Sect: _____ Twp: _____ Rg: _____ Wof: _____ Tax Roll #: _____
Directions: _____

Project Information: Commercial Residential Multi Family Industrial Institutional Oil & Gas
Type of Work: New Renovation Addition Accessory Building Basement Dev. Connection Only Temp Service Other
Service: Amperes: _____ Voltage: _____ Phase: _____ Underground Overhead

Detailed Description of Work:

Permit Applicant Declaration: The permit applicant certifies that this installation will be completed in accordance with the Alberta Safety Codes Act and Regulations and work will commence within 90 days. The permit applicant/owner acknowledges that as per Section 12(2) of the Alberta Safety Codes Act; Superior Safety Codes Inc. is not liable for any decision related to the system of inspections, examinations, evaluations and investigations including but not limited to a decision relating to their frequency and the manner in which they are carried out. The personal information provided on this form is protected by the Freedom of Information and Protection of Privacy Act.

Master's Name (Please print) _____ Master's Signature _____ Homeowner's Signature (Homeowner permits only) _____

Master's Certification Number _____

Project Value (Materials & Labour): \$ _____ Total Developed Area: _____ Sq. Ft

Permit Fee: \$ _____ *SCC Levy: \$ _____ TOTAL FEE: \$ _____

*SCC Levy is 4% of the permit fee with a minimum of \$4.50 and a maximum of \$560

Payment Method: Visa M/C Debit Cheque Cash Authorization / Cheque Number _____

Credit Card #: _____ Expiry Date: _____ Date of Authorization: _____

Name of Cardholder: _____ Signature of Cardholder: _____

Permit Validation Section to be completed by the Permit Issuer: HB
Special Conditions: _____

Permit Issuer's Name (print or type) _____ Permit Issuer's Signature _____
Permit Issuer's Designation Number: _____ Date of Issue (M/D/Y): _____

Calgary	25, 2015 – 32 Avenue NE	T2E 6Z3	Ph: 403.717.2344	Toll Free Ph: 1.888.717.2344	Fax: 403.717.2340	Toll Free Fax: 1.888.717.2340
Edmonton	14613 – 134 Avenue	T5L 4S9	Ph: 780.489.4777	Toll Free Ph: 1.866.999.4777	Fax: 780.489.4711	Toll Free Fax: 1.866.900.4711
Fort McMurray	165, 101 Signal Road	T9H 4N6	Ph: 780.715.7726	Toll Free Ph: 1.877.715.7726	Fax: 780.715.7731	Toll Free Fax: 1.877.815.7731
Grande Prairie	1 st Floor 10525 – 100 Avenue	T8V 0V8	Ph: 780.882.8777	Toll Free Ph: 1.877.882.8777	Fax: 780.882.7677	Toll Free Fax: 1.877.882.8775
Lethbridge	422 North Mayor Magrath Dr.	T1H 6H7	Ph: 403.320.0734	Toll Free Ph: 1.877.320.0734	Fax: 403.320.9969	
Lloydminster	Bay 1, 2914 – 50 Avenue	T9V 2S5	Ph: 780.870.9020		Fax: 780.870.9036	
Red Deer	3, 6264 – 67A Street	T4P 3E8	Ph: 403.358.5545	Toll Free Ph: 1.888.358.5545	Fax: 403.358.5085	Toll Free Fax: 1.866.358.5085



#3, 6264-67A Street
 Red Deer, AB T4P 3E8
 Ph. 403.358.3545 Fax 403.358.3085
 Toll Free Ph 1.888.358.5545
 Toll Free Fax 1.866.358.5085

Solid Fuel Burning Appliance Information
 (please complete as much information as possible and submit with the building permit application)

1. Applicant's Name: _____
2. Municipality: _____
3. Legal Land Description Lot _____ Block _____ Plan _____
 _____ ¼ Sec _____ Twp _____ Rge _____ W of _____ Meridian
4. In the solid fuel burning appliance ULC, Warnock Hersey or CSA approved? _____
5. Please fill in the information as indicated on the diagram below

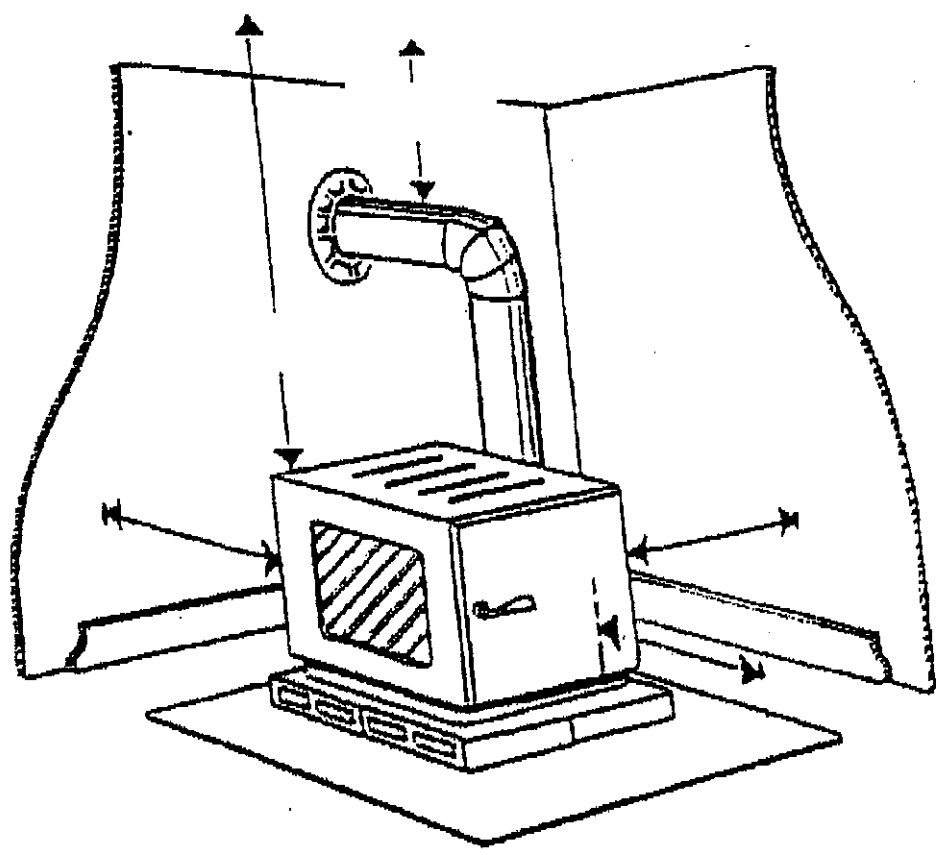

Regional Offices:

25, 2015 - 32 Avenue NE, Calgary, AB T2E 6Z3	Ph: (403) 717-2344	Fax: (403) 717-2340	Toll Free Ph: 1-888-717-2344	Toll Free Fax: 1-888-717-2340
100, 10620 - 178 Street, Edmonton, AB T4S 2E5	Ph: (780) 489-4777	Fax: (780) 489-4711	Toll Free Ph: 1-866-999-4777	Toll Free Fax: 1-866-900-4711
10325 - 100 Avenue, Grande Prairie, AB T8V 0V8	Ph: (780) 882-8777	Fax: (780) 882-7877	Toll Free Ph: 1-877-882-8777	Toll Free Fax: 1-877-882-8775
3, 6264 - 67A Street, Red Deer, AB T4P 3E8	Ph: (403) 358-3545	Fax: (403) 358-3085	Toll Free Ph: 1-888-358-5545	Toll Free Fax: 1-866-358-5085